



IPTV Feature Guide



Table of Contents

Internet Protocol Television (IPTV) Introduction	3
IPTV Set-top box (STB) Self Installation Guide	3
Remote Control Functions	4
Remote Control Functions	5
Basic Operation Tips	6
Programming Your Remote	8
Quick Setup	8
Set volume buttons to always control the same device	8
Setting up Parental Controls	9
Access Parental Controls Screen	9
Parental Locking	9
Rental Locking	11
Adult Locking	11
Menu and Guide Navigation	13
Interactive Program Guide	13
One-Button Closed Captioning & Audible Navigation	14
Whole Home DVR	15
Record a Live Program	15
Schedule a Recording	15
Schedule a Series Recording	16
Remote DVR Access	16
Create a remote DVR account	16
Access the remote DVR system from your PC	17
Access the remote DVR system from your Smartphone	17
TV Caller ID	18
Enable/Disable TV Caller ID	18
Channel Favorites	19
Add Individual Channel to your Favorites	19
Add Multiple Channels to your Favorites	19
View your Favorites	19
Appendix A – Premise Wiring for IPTV	20

Internet Protocol Television (IPTV) Introduction

Bristol Tennessee Essential Services is proud to offer Internet Protocol Television (IPTV) for your home entertainment experience. Our IPTV system uses existing RF wiring inside your home to establish a network of devices to deliver rich content to your TV. For the system to function as designed, high quality RF wiring and connectors must be used. The first time IPTV is installed at your location, a BTES representative will come on-site to install equipment and test the wiring in your home. Any future changes in wiring must follow high quality standards or IPTV service may not function as designed. For additional information on how the wiring in your home should be configured to optimize your IPTV experience, please see Appendix A.

IPTV Set-top box (STB) Self Installation Guide

1. Come to BTES office and pick up an IPTV set-top box (STB).
** New IPTV customers may need to schedule an on-site installation with BTES.
2. Connect the STB to the coax wall outlet using the "RF IN" input on the rear of the STB. This step may not be necessary if you are using a wireless set-top box.
3. Connect the STB output to your TV using HDMI, component, composite or coax cables depending on your TV.
** For the best quality, BTES recommends using HDMI or component cables if your TV supports it.
4. Connect one end of the STB power cord into the STB and the other into a nearby power outlet.
5. Power on the STB.
6. Upon initial boot-up of the STB, you will see a screen that looks like the image to the right, indicating the box is in the initial boot process.
7. When the box is ready for use, you should see channel 1 with the splash screen on how to access Video on Demand.



Remote Control Functions

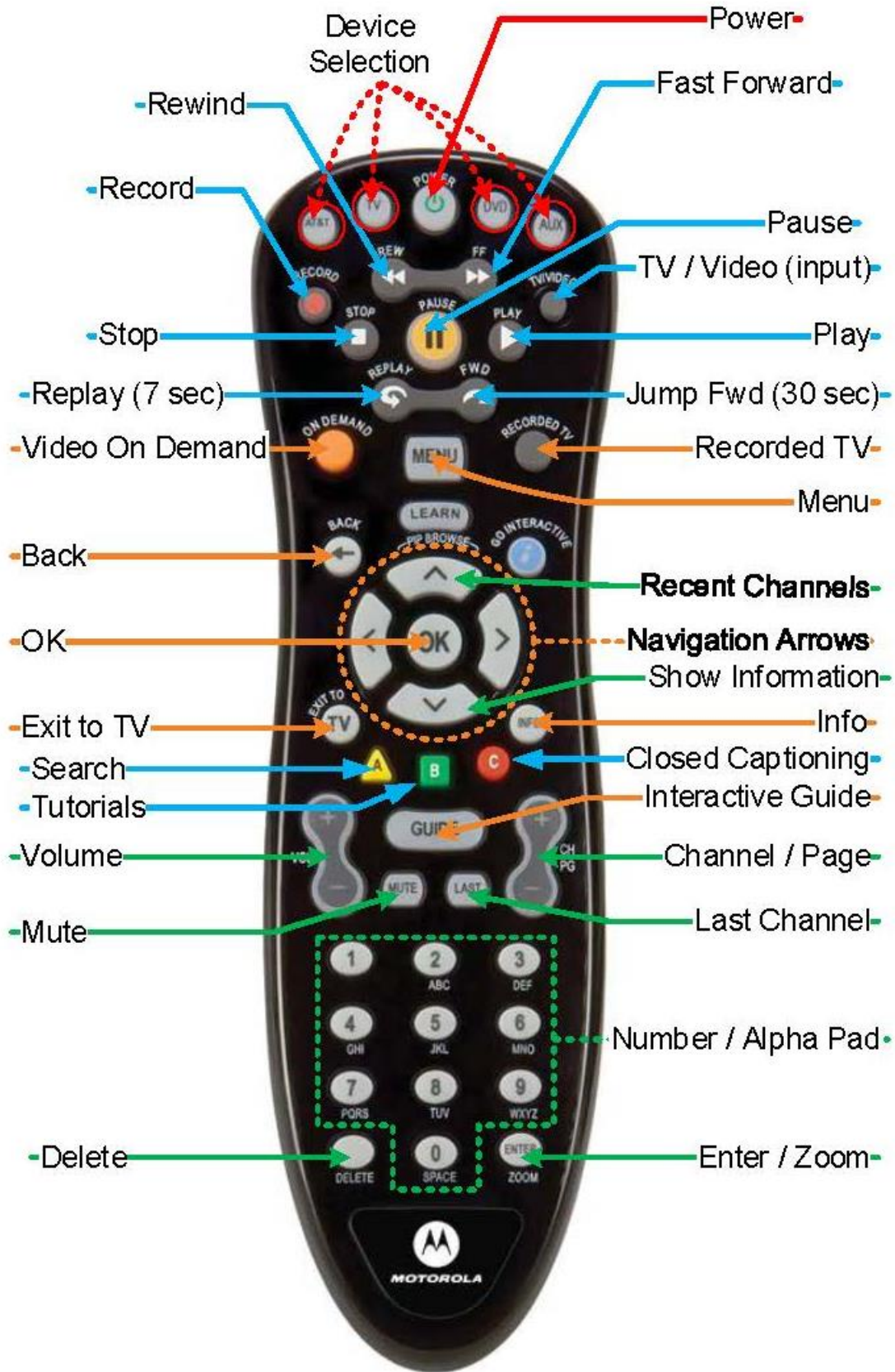

Remote Control Functions

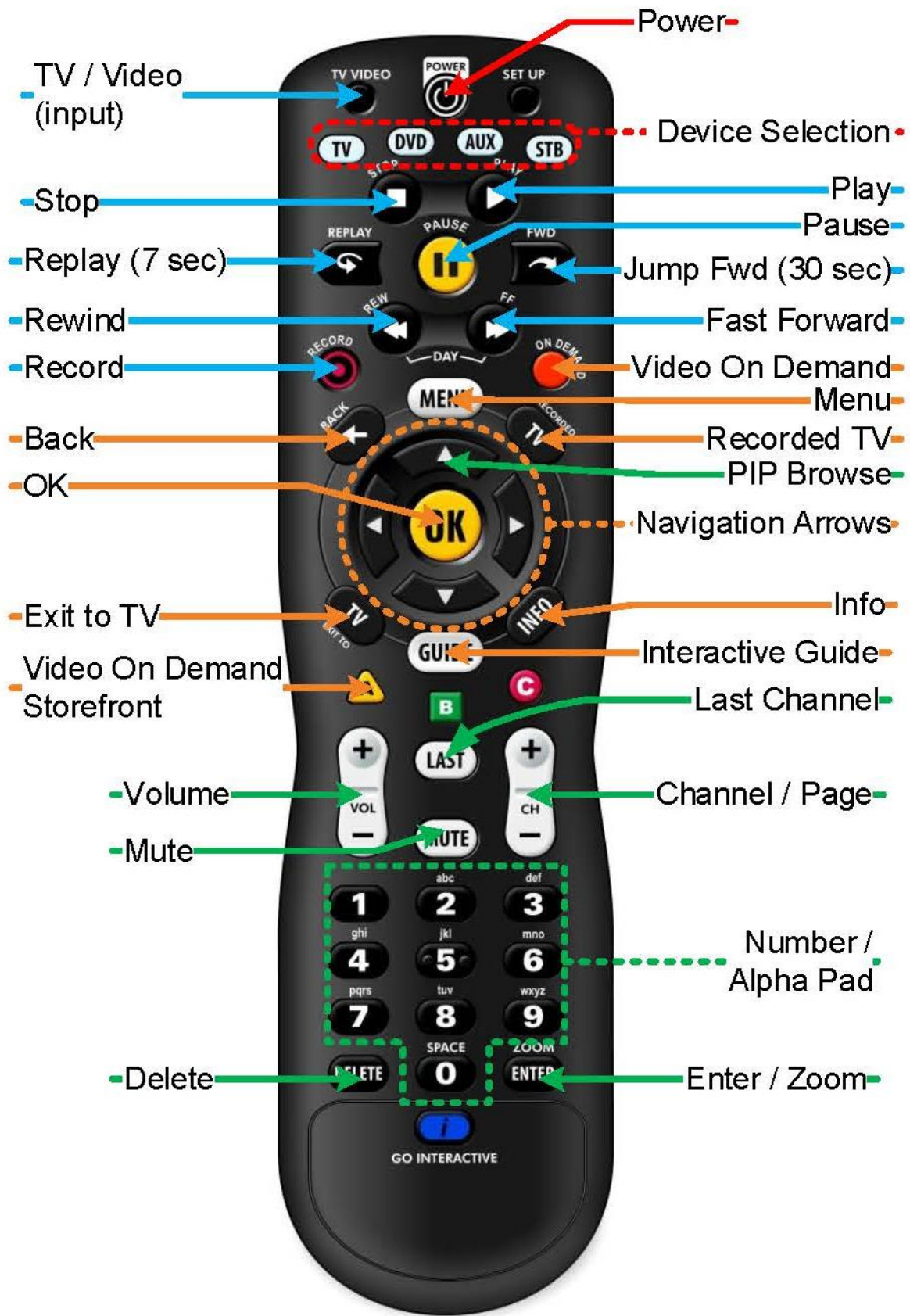

Basic Operation Tips

- STB/TV/DVD/AUX** . Device Selection buttons select the device you would like to communicate with. The remote is pre-programmed to operate the set-top box and can be programmed to operate your TV, DVD player or other Auxiliary equipment.
- Power**..... Powers on or off devices. Can be programmed to power on/off all devices with one push.
- REW/FF** Rewinds or fast forwards DVR and DVD player functions. Also used to change the day of the week in the Interactive Guide.
- Record**..... When used with a DVR, records current program or schedules future recordings.
- TV/Video**..... Changes the input when the remote is programmed to operate other devices such as your TV.
- Stop**..... Stops playback on DVR and DVD player functions.
- Pause**..... Pauses playback on DVR and DVD player functions. Also pauses live TV if you have a DVR.
- Play**..... Plays content on DVR and DVD player functions.
- Replay** Jumps back approximately 7 seconds in the active program.
- FWD**..... Jumps forward approximately 30 seconds in recorded programming.
- On Demand**..... Opens the Video on Demand application.
- Recorded TV** Opens the DVR menu, including list of recorded content and scheduled recordings.
- Menu**..... Opens the main menu screen to access the Interactive Program Guide, Recorded TV, Video on Demand, Applications and Settings.
- Setup**..... Programs the remote to operate other devices. Further directions are on the back of the remote, on the battery compartment cover.
- Back**..... Takes you back to the previous screen when navigating menus.
- Go Interactive** Button not used at this time.
- Browse** When watching live TV, this button will bring up a picture-in-picture window in the lower third of the screen to browse content on other channels. Use the Up/Down buttons to change the channel and the Right/Left buttons to change the timeframe (for guide content only).
- OK**..... Selects options in the IPTV menu structure.
- Exit to TV**..... Exits any open menu to return to watching the currently selected programming.
- Info**..... Provides program information on live TV, recorded content, and Video on Demand content, including title, episode description, cast list, time remaining on active content, original air date, etc.
- A**..... Quick access to “Search” option.
- B** Quick access to BTES “How To” Video Library.
- C** Quick access to turning on or off closed captioning.
- Guide**..... Quick access to the Interactive Program Guide.
- Ch/Pg**..... The Channel / Page up and down buttons are used for changing channels as well as scrolling through pages within the menus such as the Interactive Guide, Recorded TV, and Video on Demand.
- Vol**..... Adjusts volume on either Television or Set Top Box

Mute Silences the audio

Last..... This will jump to the channel being watched immediately before the current one. It will also bring up a picture-in-picture window with a listing of the last five channels watched.

Number Pad..... Allows the user to enter a specific channel number to jump to. Can also be used as an alphanumeric pad when using the Search feature (0 is Space).

Delete..... Used to delete the last entered character in the Search field or delete a previously recorded program in the Recorded TV list.

Enter/Zoom When selecting a specific channel, pressing Enter will jump to the desired channel immediately instead of waiting for the timeout period. When watching a program, the Zoom function provides quick access to your Favorite channels and setting the aspect ratio for your device.

Programming Your Remote

Quick Setup

1. Press and hold SETUP until LED light blinks twice.
2. Press a mode key (TV, DVD, or AUX).
3. Press and hold OK key until the device turns off.

Set volume buttons to always control the same device

You can program your remote to control your TV volume or surround sound receiver volume directly rather than using the volume control on the STB.

1. Turn the STB volume all the way up ("25" is the maximum level).
2. Press and hold down the TV mode key; press OK for 1 second.
3. Release both keys. All of the mode keys will flash followed by the TV mode key light remaining on.
4. Press and hold the MUTE key for 3 seconds until the TV mode key light briefly turns off then remains on.
5. Press and release the mode key that you always want to operate the volume commands (STB, TV, DVD and AUX). The selected mode key light will remain on.
6. Press and release the MUTE key to save the setting. The selected mode key light will turn off indicating a successful setup.

The volume commands will be setup for the selected device despite what mode is selected. If the selected mode key light flashes for three seconds and turns off, then the selected mode will have no volume commands of its own and will need to start over from step 1 above and select a different mode to program the device.



Setting up Parental Controls

Parental controls allow you to restrict access to content and movie rentals based on your desired level of control. This will also block the associated content title and descriptions from appearing in the interactive program guide.

Access Parental Controls Screen

1. Press “Menu” on the STB remote.
2. Scroll down using the “Down Arrow” button and highlight “Settings.”
3. Scroll down using the “Down Arrow” button and highlight “Parental Controls.”
4. Press “OK” to select.
5. Scroll to select the desired function from either “Parental Locking,” “Rental Locking” or “Adult Locking.”
6. Press “OK” to select and enter your PIN. By default, your PIN is set to “0000” for each section. The user can change these codes so each type of blocking has a different PIN.

For Example: (Default)

Parental Locking:	“1234”	“0000”
Rental Locking:	“4321”	“0000”
Adult Locking:	“5678”	“0000”



Parental Locking

The Parental Locking feature allows you to block content based on the channel number, US TV Parental Guideline ratings, Movie Ratings and content that is not rated.

Block Specific Channels

1. Browse to the Parental Locking screen (see prior instructions).
2. Use the navigation arrows to highlight the “Change” button in the Channels block.
3. Press “OK.”
4. Use the navigation arrows to highlight a channel you want blocked.

Tips:

- a. You can also use the “Channel Up/Down” buttons to scroll from one page to another on the channel screen.
 - b. Before saving your blocked channel selection, you can select the “View Locked Only” button on the left side of the screen to confirm your selections in a consolidated view.
5. Press “OK” and you will see a “LOCK” icon next to the channel.
 6. Repeat steps 4 and 5 to block additional channels.
 7. Once all channels have been selected for blocking, use the navigation arrows to select the “Save” button on the left side of the screen. You will now return to the Parental Locking home screen.
 8. To return to Live TV, press the “Exit to TV” button on the remote control.

Remove Block from Specific Channels

1. Browse to the Parental Locking screen (see prior instructions).
2. Use the navigation arrows to highlight the “Change” button in the Channels block.
3. Press “OK.”
4. Use the navigation arrows to highlight the “View Locked Only” button on the left side of the screen.
5. Press “OK.”
6. Use the navigation arrows to highlight a channel you want unblocked.
7. Press “OK” and you will see the “LOCK” icon next to the channel be removed.

8. Repeat steps 6 and 7 to unblock additional channels.
9. Once all desired channels have been unblocked, use the navigation arrows to select the “Save” button on the left side of the screen. You will now return to the Parental Locking home screen.
10. To return to Live TV, press the “Exit to TV” button on the remote control.

Remove Block from All Channels

1. Browse to the Parental Locking screen (see prior instructions).
2. Use the navigation arrows to highlight the “Change” button in the Channels block.
3. Press “OK.”
4. Use the navigation arrows to highlight “Unlock All.”
5. Press “OK.”
6. Use the navigation arrows to select the “Save” button on the left side of the screen. You will now return to the Parental Locking home screen.
7. To return to Live TV, press the “Exit to TV” button on the remote control.

Block TV shows based on US TV Parental Guideline Ratings

1. Browse to the Parental Locking screen (see prior instructions).
2. Use the navigation arrows to highlight the “Change” button in the US TV Parental Guidelines block.
3. Press “OK.”
4. Use the navigation arrows to highlight the lowest level rating you want to block. *NOTE: Everything above this point will be blocked also. For instance, if you block TV-PG content, TV-14 and TV-MA will be blocked also.*
5. Press “OK” and you will see the “LOCK” icon appear next to each rating type that will be blocked.
6. Use the navigation arrows to select the “Save” button on the left side of the screen. You will now return to the Parental Locking home screen.
7. To return to Live TV, press the “Exit to TV” button on the remote control.

Block Movies based on their Ratings

1. Browse to the Parental Locking screen (see prior instructions).
2. Use the navigation arrows to highlight the “Change” button in the Movie Ratings block.
3. Press “OK.”
4. Use the navigation arrows to highlight the lowest level rating you want to block. *NOTE: Everything above this point will be blocked also. For instance, if you block PG-13 content, R and NC-17 will be blocked also.*
5. Press “OK” and you will see the “LOCK” icon appear next to each rating type that will be blocked.
6. Use the navigation arrows to select the “Save” button on the left side of the screen. You will now return to the Parental Locking home screen.
7. To return to Live TV, press the “Exit to TV” button on the remote control.

Block All Unrated Content

1. Browse to the Parental Locking screen (see prior instructions).
2. Use the navigation arrows to highlight the “Change” button in the Unrated Content block.
3. Press “OK.”
4. By default, the “Lock unrated programming” box will be highlighted.
5. Press “OK” and you will see the “LOCK” icon appear.

6. Use the navigation arrows to select the “Save” button on the left side of the screen. You will now return to the Parental Locking home screen.
7. To return to Live TV, press the “Exit to TV” button on the remote control.

Un-Block All Unrated Content

1. Browse to the Parental Locking screen (see prior instructions).
2. Use the navigation arrows to highlight the “Change” button in the Unrated Content block.
3. Press “OK.”
4. By default, the “Lock unrated programming” box will be highlighted.
5. Press “OK” and you will see the “LOCK” icon disappear.
6. Use the navigation arrows to select the “Save” button on the left side of the screen. You will now return to the Parental Locking home screen.
7. To return to Live TV, press the “Exit to TV” button on the remote control.

Rental Locking

The Rental Locking feature allows you to restrict the ability to purchase Pay-Per-View and Video on Demand content so that purchases can only be made by users who know the PIN.

Enable Rental Locking

1. Browse to the Parental Controls screen (see prior instructions).
2. Scroll to select the “Rental Locking” button.
3. Press “OK” to select and enter your PIN. By default, your PIN is set to “0000.”
4. By default, the “Lock renting” box will be highlighted.
5. Press “OK” and you will see the “LOCK” icon appear.
6. Use the navigation arrows to select the “Save” button on the left side of the screen. You will now return to the Parental Locking home screen.
7. To return to Live TV, press the “Exit to TV” button on the remote control.

Disable Rental Locking

1. Browse to the Parental Controls screen (see prior instructions).
2. Scroll to select the “Rental Locking” button.
3. Press “OK” to select and enter your PIN. By default, your PIN is set to “0000.”
4. By default, the “Lock renting” box will be highlighted.
5. Press “OK” and you will see the “LOCK” icon disappear.
6. Use the navigation arrows to select the “Save” button on the left side of the screen. You will now return to the Parental Locking home screen.
7. To return to Live TV, press the “Exit to TV” button on the remote control.

Adult Locking

The Adult Locking feature allows you to block content that is adult oriented and not intended for younger audiences, such as content that is rated TV-MA or unrated (NR) content.

Enable Adult Locking

1. Browse to the Parental Controls screen (see prior instructions).
2. Scroll to select the “Adult Locking” button.

3. Press "OK" to select and enter your PIN. By default, your PIN is set to "0000."
4. By default, the "Adult Locking" box will be highlighted.
5. Press "OK" and you will see the "LOCK" icon appear.
6. Use the navigation arrows to select the "Save" button on the left side of the screen. You will now return to the Parental Locking home screen.
7. To return to Live TV, press the "Exit to TV" button on the remote control.

Disable Adult Locking

1. Browse to the Parental Controls screen (see prior instructions).
2. Scroll to select the "Adult Locking" button.
3. Press "OK" to select and enter your PIN. By default, your PIN is set to "0000."
4. By default, the "Adult Locking" box will be highlighted.
5. Press "OK" and you will see the "LOCK" icon disappear.
6. Use the navigation arrows to select the "Save" button on the left side of the screen. You will now return to the Parental Locking home screen.
7. To return to Live TV, press the "Exit to TV" button on the remote control.

Menu and Guide Navigation

Your IPTV set-top box has an advanced menu system with many dynamic options which can be easily accessed and controlled from your remote control.

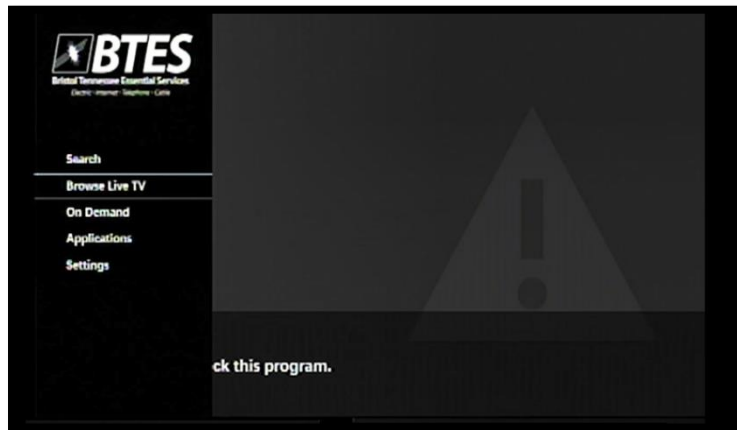

Interactive Program Guide

Access the Guide by pressing the “Guide” button on the remote control. Up to two weeks of programming may be accessible from the guide, though some content is subject to change when it is further out.

Program Guide Navigation

- The “Up/Down” navigation arrows can be used to move from channel to channel. The “Left/Right” arrows will shift the timeframe to look at future programming.
- To jump to a specific **date** in the program guide, press “ENTER” and select “Jump to day.” Navigate to the desired option and press “OK.”
- To quickly change the **date** of the program guide, use the “REW” to move to a previous date and “FF” to move to a future date.
- To **scroll** through the channel blocks, press the “Channel Up/Down” button in the desired direction. This will jump a full page with each button press.
- To jump to a specific channel, key in the channel number on the number pad and press “OK.”



Search for a specific program or actor

You can search the interactive guide by program name, cast member, description, etc.

1. Press “A” on your remote.
2. Enter the program name.

Using the alphanumeric keypad on your remote

- Spell the name of the program or actor. For “NCIS” you would press the following numbers: “6, 6” “2,2,2” “4,4,4” “7,7,7,7”
- To backspace, use the “Delete” button on the remote

Using the navigation arrows on the screen

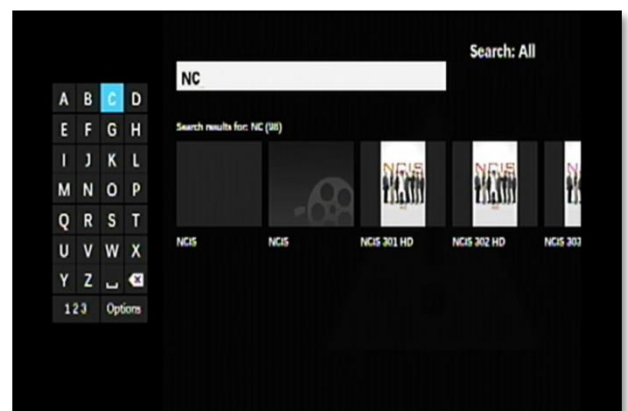

- Spell the name of the program by using the navigation arrows to move the highlighted cursor over each letter and press “Enter” after each letter.
 - To backspace, use the “Delete” button on the remote.
3. The list will automatically filter after each letter is entered, so it may not be necessary to spell the entire program. Once you see the desired program appear, use the navigational arrows to access search results and highlight the program.
 4. Press “OK” to see a list of the upcoming schedule for this program.
 - To get information about a specific episode, highlight the episode and press “INFO.”
 - If you have DVR service, you can schedule recordings of specific episode by highlighting the episode and pressing “Record” once. You will see a red dot appear. You can schedule the entire series to record by highlighting the episode and pressing “Record” twice. You will see a cascade of 3 red dots appear. To cancel a scheduled recording, press “Record” a third time.
 5. To return to Live TV, Press the “Exit to TV” button on the remote control.

Remove select channels from the Program Guide

In addition to parental block of specific channels, you may want to also remove some channels from the guide completely.

1. Press “GUIDE” on the remote control.
2. Press “ENTER” and the Guide Options menu will appear.
3. Scroll down and highlight “Guide Settings.”
4. Press “OK.”
5. Highlight “Customize Channels.”
6. Press “OK” - Every channel that currently appears in the program guide will have a check mark next to it.
7. Scroll to each channel that you want to remove and press “OK.” The check mark will disappear.
8. Once you have selected the channels to add or remove from the Program Guide, navigate to and highlight the “Save” button on the left of the screen.
9. Press “OK.”

One-Button Closed Captioning & Audible Navigation

One-Button Closed Captioning

To enable or disable Closed Captioning, press the “C” Button on your remote

Audible Navigation

This feature is only available on the Arris VIP5662W (Wireless DVR) and Arris 5602W (Wireless HD Box) models. When enabled, a descriptive audio voice will play, reading the selected menu or guide options.

To Enable/Disable Audible Navigation

1. Press the “Menu” button on the remote.
2. Using the “down arrow” scroll to “Settings” and then “Audio.”
3. Use the “Right arrow” to scroll to “Audible Navigation.”
4. Press “OK.”
5. Using the “Right arrow” scroll to select “Enable” or “Disable.”
6. Press “OK.”



Whole Home DVR

If you subscribe to DVR service, our IPTV system is equipped with the Whole Home DVR feature. With this feature, only one DVR set-top box is needed to record, playback and schedule programming from ANY IPTV set-top box in your home. Recordings can be scheduled from multiple places within the IPTV system. A few of the most common places are outlined below. When a program is being recorded, the red light labeled "RECORD" will be lit on the front of the STB.

Record a Live Program

While watching a live program, press the "Record" button on the remote control once to begin recording the current program. A banner will briefly appear at the top of the screen showing "Recording" to confirm the recording has begun.

Pause live TV and playback from a different room

Whole Home DVR stores up to 60 minutes of the live TV channel you're tuned to. While watching the TV connected to your STB, you can rewind live TV by pressing "REW" on your remote.

Press the "Pause" button on your remote control and the live TV you are watching will be paused for up to 60 minutes. Users can control playback of the paused channel from any room.

Schedule a Recording

Basic

1. Press the "GUIDE" button on the remote control.
2. Browse to find the desired program to record using the navigation arrows.
3. Press the "RECORD" button on the remote control **once**.
4. A banner will briefly appear at the top of the screen showing "Recording scheduled" to confirm the recording and a RED dot will appear on the guide next to the program.

Advanced

1. Press "GUIDE" on the remote control.
2. Browse to find the desired program to record using the navigation arrows.
3. Press "INFO"
4. Use the navigation arrows to highlight the "Record episode" button.
5. Press "OK."
6. Verify the information on the screen that comes up.
 - a. CHANNEL – indicates the channel where the program will air.
 - b. TIME – Indicates the time frame the DVR will record.
 - c. STOP RECORDING – adjust the length of time added to the end of this scheduled recording (can be used to avoid missing the end of a program that exceeds the scheduled time).
 - d. KEEP – adjust how the STB manages that recorded program before it is automatically deleted.
7. Use the navigation arrows to highlight the "Record" button and press "OK" on the remote control.
8. A banner will briefly appear at the top of the screen showing "Recording scheduled" to confirm the recording and a RED dot will appear on the guide next to the program.



Schedule a Series Recording

Basic

1. Press the "GUIDE" button on the remote control.
2. Browse to find the desired program to record using the navigation arrows.
3. Press the "RECORD" button on the remote control **twice**.
4. A banner will briefly appear at the top of the screen showing "Series recording scheduled" to confirm the recording and a cascade of three red dots will appear on the guide next to the program.

Advanced

1. Press "GUIDE" on the remote control.
2. Browse to find the desired program to record using the navigation arrows.
3. Press "INFO"
4. Use the navigation arrows to highlight the "Record series" button.
5. Press "OK"
6. Verify the information on the screen that comes up and adjust as needed:
 - a. CHANNEL – indicates the channel where the program will air.
 - b. TIME – adjust what time frames the DVR should search to find this program to record.
 - c. SHOW TYPE – adjust to record only new episodes or to include reruns also.
 - d. STOP RECORDING – adjust the length of time added to the end of this scheduled recording (can be used to avoid missing the end of a program that exceeds the scheduled time).
 - e. KEEP – adjust how the STB manages that recorded program before it is automatically deleted.
7. Use the navigation arrows to highlight the "Record" button and press "OK" on the remote control.
8. A banner will briefly appear at the top of the screen showing "Series recording scheduled" to confirm the recording and a cascade of three red dots will appear on the guide next to the program.

Remote DVR Access

BTES offers remote access to your DVR! This feature allows customers to schedule recordings, view a listing of current recordings, delete recordings, search for programs and more. Before the remote DVR function can be used, a user account must be established from your IPTV set-top box.

Create a remote DVR account

1. Press "Menu" on the remote.
2. Using the "Down Arrow," scroll and highlight "Applications" and then scroll down to "Remote DVR."
3. Press "OK" to select.



The screenshot shows the "Remote DVR" interface on a set-top box. At the top, it says "Alcatel Lucent" and "Remote DVR" with the time "12:39 PM". Below that is a header "Create / Change user". On the left is a virtual alphanumeric keypad. On the right is a form with three input fields: "User name", "Password", and "Confirm password". Below the "Confirm password" field, there are two lines of text: "User name must contain from 6 to 8 characters" and "Password must contain from 6 to 8 characters". At the bottom of the form is a "Save" button.

4. In the "User name" field, enter your desired username using the remote's alphanumeric pad.

- In the "Password" field, enter your desired password. Re-enter your password in the "Confirm Password" field.
** Your password must be between 6-8 characters.
- Navigate to the "Save" button and press "OK" on the remote control.

Access the remote DVR system from your PC

- From a web browser or mobile device go to <http://dvr.btes.tv>
- Select "RDVR Access from your PC"
- When prompted, enter your username and password that was created on the STB.



Access the remote DVR system from your Smartphone

- From a web browser or mobile device go to <http://dvr.btes.tv>
- Select "RDVR Access from your Mobile Phone Browser"
- When prompted, enter your username and password that was created on the STB.



TV Caller ID

TV Caller ID displays incoming call information on your television screen, if you subscribe to this feature.

Enable/Disable TV Caller ID

1. Press “Menu” on the remote.
2. Using the “Down Arrow,” scroll to select “Applications” and then “CallerID.”
3. Press “OK” to select

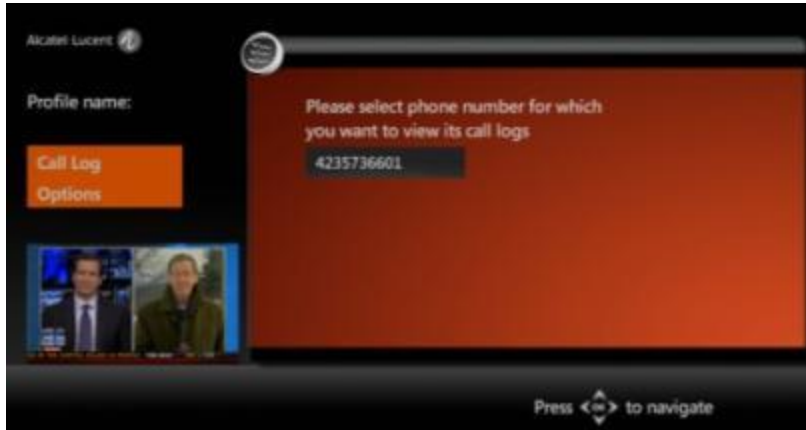

4. Scroll using the “Left Arrow” button and highlight “Options”
5. Press “OK”
6. Scroll down and highlight “Active numbers”
7. To Enable/Disable this feature, press “OK” on the remote. If the box is checked, TV Caller ID is enabled, and caller information will display on your television when you receive an incoming call. If the box is unchecked, caller information will not display.
8. Highlight the “Done” button and press “OK” on the remote.
9. To return to Live TV, press the “Exit to TV” button on the remote control.



Channel Favorites

For easy access to your most watched channels, create a list of favorites that are accessible from your remote.

Add Individual Channel to your Favorites

1. Tune the STB to the desired channel.
2. Press "ENTER" on the remote.
3. A side-menu will appear. Highlight the "Add to favorites" button and press "OK."

Add Multiple Channels to your Favorites

1. Press "ENTER" on the remote.
2. A side-menu will appear. Highlight the "Edit favorites" button and press "OK."
3. Use the navigation arrows to highlight the box next to the first channel you want to add.
4. Press "OK"
Tip: You can use the "Channel Up/Down" buttons to scroll.
5. Repeat steps 3-4 for each channel you want added into the favorites list.
6. Use the navigation arrows to highlight the "Save" button on the left of the screen.
7. Press "OK"
8. You should now see a customized guide with only your favorite channels listed.

View your Favorites

1. Press "MENU" on the remote.
2. Use the "Down Arrow" to scroll and highlight "Browse Live TV."
3. Use the "Down Arrow" to select "Favorites"
4. Use the navigation arrows to highlight the "Favorites" button and press "OK."

Appendix A – Premise Wiring for IPTV

The first time IPTV is installed at your location, a BTES representative will come on-site to install equipment and test the wiring in your home. Any future changes in wiring must follow the same high quality standards or you may not experience the IPTV service as designed. Shown below is a diagram of a typical IPTV premise configuration.

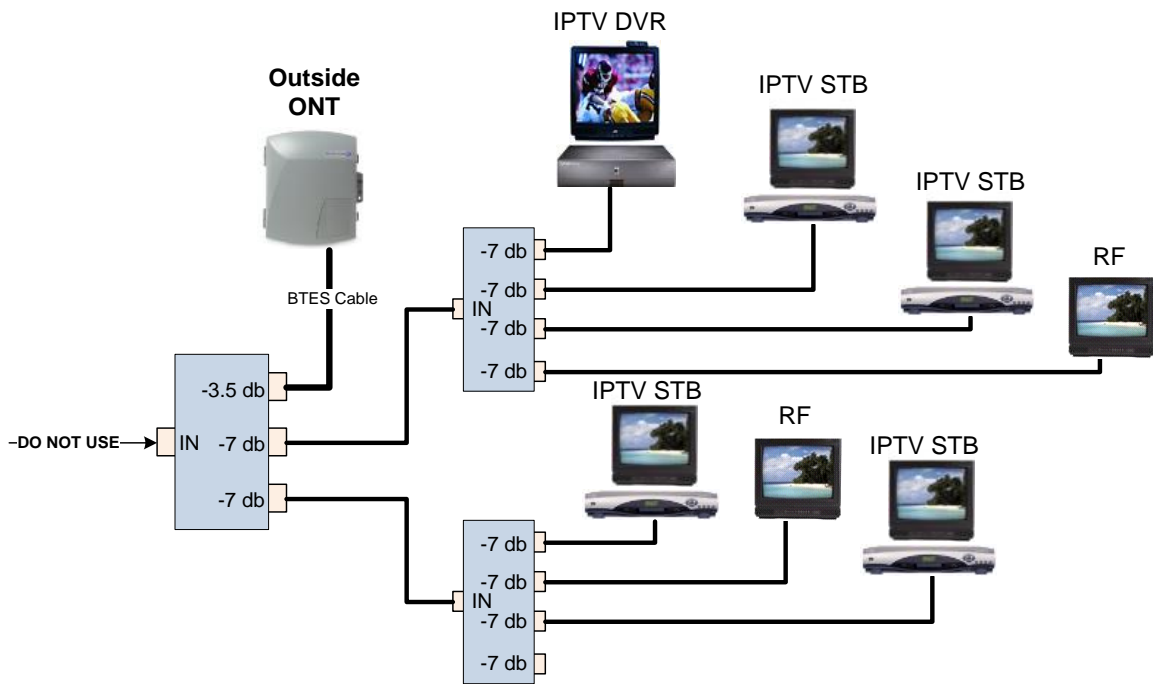

The important things to know about premise wiring for IPTV are:

- The input is NOT used on the first splitter. Instead the main cable line coming into the premise is connected to the output on the first splitter. This is critical to the proper operation of IPTV.
- The quantity of splitters should be used sparingly and as evenly dispersed as possible. Cascading more than 3 splitters in a row can cause pixilation and channels to drop periodically.
- High quality RG6 cable should be used whenever possible and ONLY compression style fittings should be installed. Twist-on or crimp style fittings can often be sources of interference and signal leaks. Fittings should also be securely tightened (but not over tightened).

Example of a poor splitter configuration:

